



  
**CARPANO**  
EQUIPMENT  
welding automation

| ENG

**OAK**

Head and tailstock positioner  
with automatic elevation  
3 And 6 ton capacity

[carpano.it](http://carpano.it)



## Head and tailstock positioner with automatic elevation 3 And 6 ton capacity

Oak is a new head and tailstock positioner with automatic elevation

- The two columns are made of strong steel carpentry with steel guides and guidance bearings
- Elevation transmission consists in trapezoidal screw + nut screw
- Safety anti-fall system by safety nut screw and wear reading
- Rotation of headstock turntable is powered at variable speed, while the tailstock one is idle.  
On request it is possible to motorize and synchronize the rotation of both the tables.
- As option, it is available a remote control pendant with touch screen, by which you can program a positioning sequence

We reserve the right of modifying the technical features of machinery as stated herein and we do not respond for any printing mistake.

**All rights reserved.** Text and images can be reproduced only after our written authorization.

An updated version of this catalogue is always available inside our website.

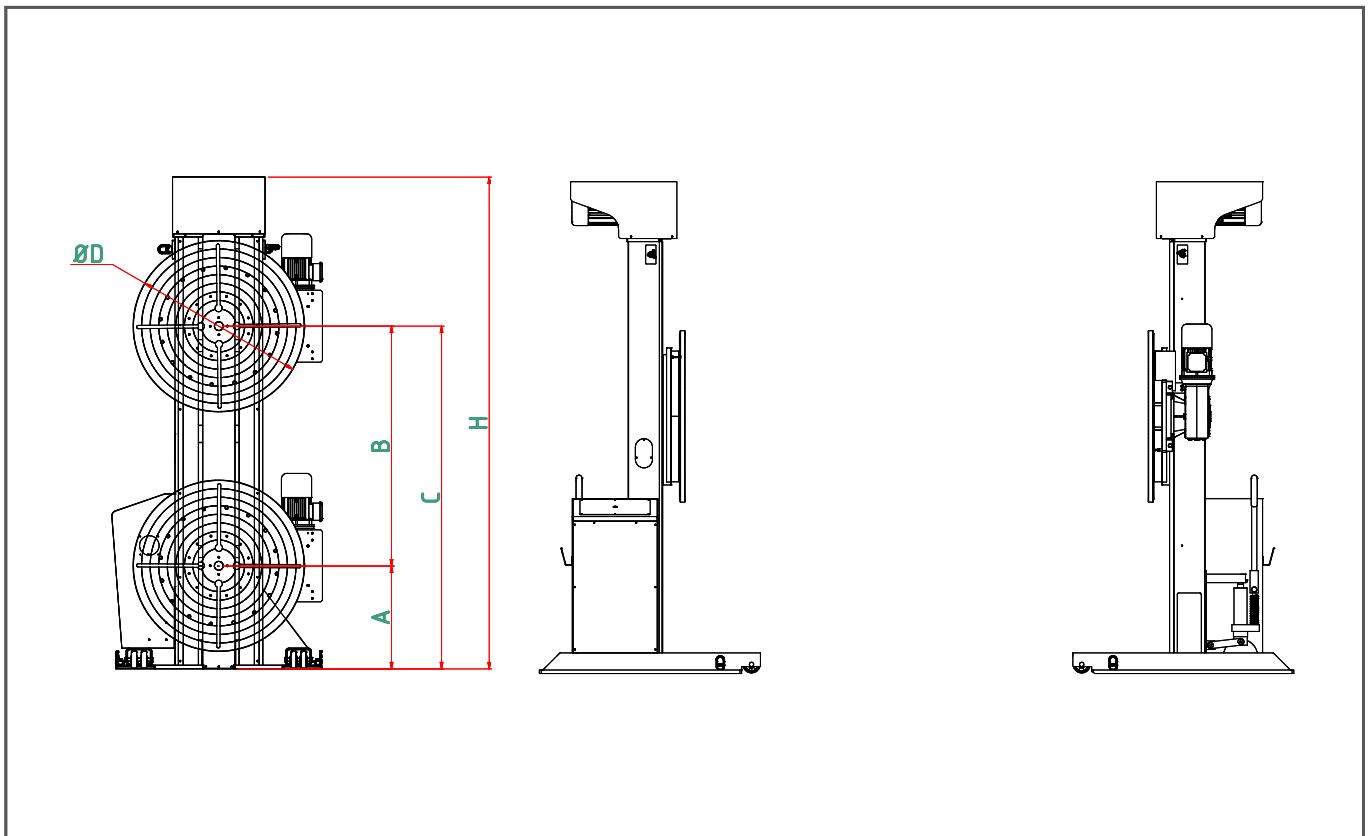

Model	OAK3	OAK6
<b>Weight</b>	headstock: about 850 kg tailstock: about 800 kg	headstock: about 1300 kg tailstock: about 1200 kg
<b>Max carrying capacity</b>	3000 kg	6000 kg
<b>Rotation speed</b>	0.1 – 1 rpm	0.1 – 1 rpm
<b>Rotation torque</b>	260 kgm	500 kgm
<b>Lifting speed</b>	560 mm/min	450 mm/min
<b>H – height of the machine</b>	2675 mm	2870 mm
<b>A – min. height of rotation axis</b>	500 mm	600 mm
<b>B – vertical stroke</b>	1400 mm	1400 mm
<b>C – max. height of rotation axis</b>	1900 mm	2000 mm
<b>D – table diameter</b>	800 mm	1000 mm
<b>Feeding voltage</b>	400V 3-phases	400V 3-phases
<b>Remote control pendant</b>	24V – 10m cable	24V – 10m cable

## Details Features



The movement of the two machines is particularly easy because of the manual lifting device, useful even when changing the sizes of the workpieces.

The shape of the bases also allows handling through the forks of a forklift.

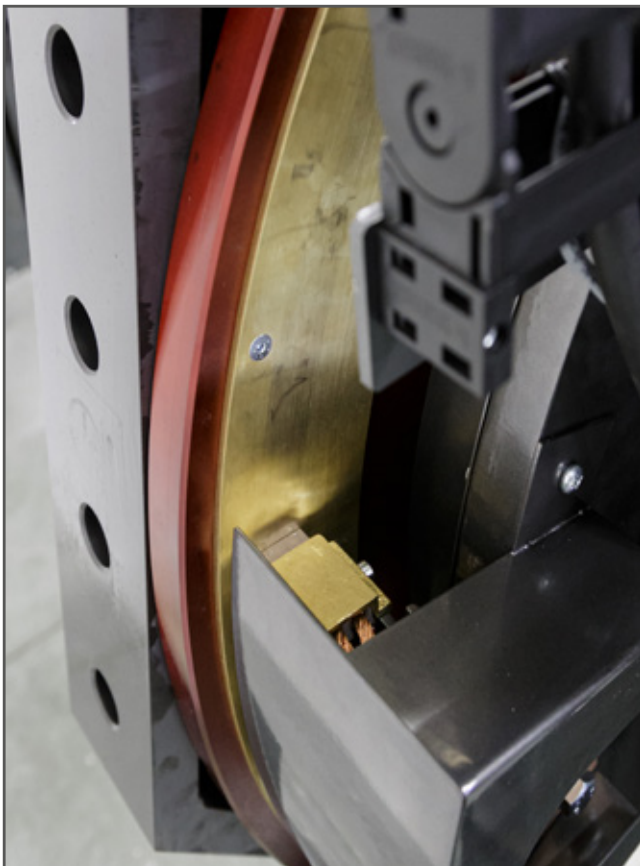

Both the columns are provided with ground bearing: carbon/graphite brushes are kept under pressure against a brass surface to prevent oxidation during inactivity.

Ground bearings capacity is usually 400A @ 60%. For different capacities, please, call on our Technical Office.

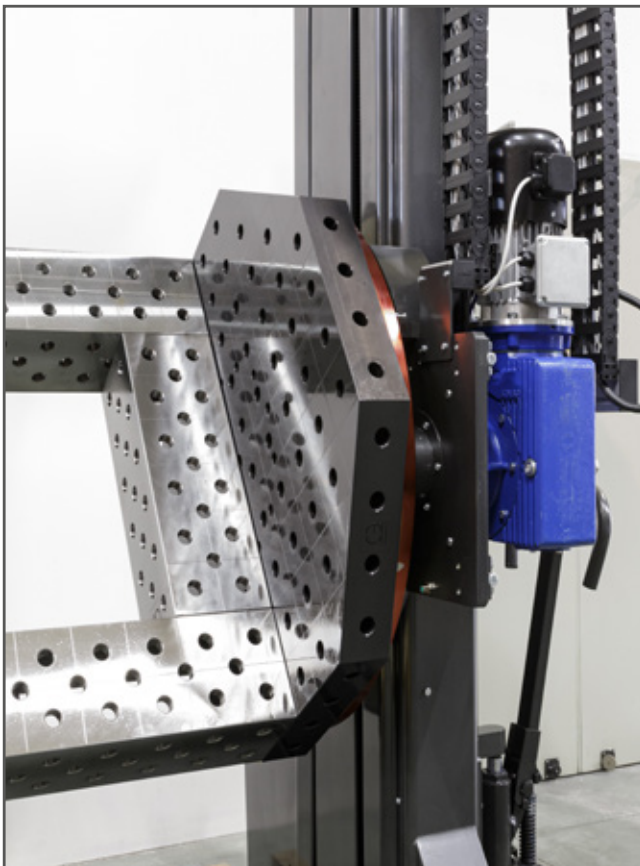

The use of octagonal tables and / or multi-hole bars gives the device great flexibility in the placement of the pieces.

They are suitable for all the accessories of DESK28 product range.

Octagonal tables and multi-hole bars are available both in natural steel and with Nitriding treatment and oxidation.

For more information please consult DESK28 catalogue.

The weight of such equipment affects the overall capacity of the machines.

■ Technical details





## 1. SUPPLY OBLIGATION ARRANGEMENT

The following general terms of business are always to be considered applicable to every order made by the buyer. Therefore, any supply clause written by the buyer on his orders or any other document given to the seller, which may result to be conflicting with the present general conditions, will be considered not written. The buyer has to forward the orders to the seller in writing. The seller reserves the authority to accept telephone and verbal orders. The order is to be considered executed when the buyer receives the written acceptance of the same (order confirmation) by the vendor or, in the absence thereof, automatically 15 days after the order receipt by the seller. All offers and prices are just an indication and are not binding. Therefore the seller considers himself to be bound only to what is declared in his order confirmations.

## 2. TERMS FOR DELIVERY

The delivery dates indicated by the seller as well as the ones written on the buyers' orders have to be considered just as an indication and are not binding and are subject to the punctual supply by the buyer of all the specifics, to the variations due to the availability of the goods with the suppliers or to reasons of force majeure: delays in the delivery due to said availability variations are not attributable to the seller, who is not in duty bound to the compensation for damages suffered by the buyer. Reasons of force majeure have also to be considered the accidents (industrial injury, disease, etc) and any other circumstances which may cause a total or partial job reduction, as well as the lack of raw materials, troubles with transportation, etc. The seller reserves the authority to suspend the delivery of the goods if the buyer has not seen to the payment of the invoices relative to other supplies whose terms of payment are overdue. The goods are understood as being delivered for all intents and purposes to the buyer from the time they were picked up by the carrier or the buyer himself at the seller's warehouse.

## 3. PAYMENT AND TERMS OF PAYMENT

The payments have to be made to the seller's domicile and in accordance with the established conditions. In the event of a delay, the due amounts of money will automatically imply the charge of interests based on the official discount rate plus 5 points. In the event of a non-payment, the buyer is to be considered in default without the necessity of any formal notice by the seller. The presence of possible faults and/or defects in the products does not excuse the buyer for suspending the payment of the invoices. Should the client suspend and/or delay the payments, the seller may suspend the supplies, with the authority to consider the contract automatically terminated by rights and to demand for damages.

## 4. WARRANTY

CARPANO EQUIPMENT guarantees the products for a period of 24 months starting from the delivery date, for a daily work cycle of 8 hours. The warranty is intended ex works CARPANO EQUIPMENT. CARPANO EQUIPMENT guarantees the performance of its products in accordance with the instructions written in the relative manuals. For the products based on job orders, the warranty is pertaining to the specifics agreed with the client.

## 5. VOID WARRANTY

In case of any tampering or unauthorized intervention the warranty shall be deemed void.

## 6. LIABILITY FOR DAMAGE

The seller's liability is limited only to the obligations above and it's expressly agreed that the seller does not accept any liability for damages resulting from any cause connected with the use and utilization of the sold products.

CARPANO EQUIPMENT is not responsible and for no reason whatsoever may the expenses be charged for:

- Machine downtime.
- Direct or in direct damage due to the non-operation of the equipment.
- Working hours spent to solve possible problems on the equipment.

## 7. RESERVATION OF OWNERSHIP

Until the payment in full of any credit resulting from business relations has taken place, included any additional credit and until the payment of bills and cheques has been made, the property in the goods remains in the seller.

## 8. COMPETENT COURT

It's established that the court of Bologna will be the sole competent court for every dispute relative to this contract.

## 9. APPLICABLE LAWS

The applicable law is the Italian law.

**CARPANO EQUIPMENT Srl**  
via del Legatore, 7 / 40138 Bologna - Italy  
tel. +39 051 6053215 - info@carpano.it



**CARPANO EQUIPMENT Srl**

Via del Legatore, 7 / 40138 Bologna Italy

T. +39 051 6053215 / e-mail: [info@carpano.it](mailto:info@carpano.it)

**[carpano.it](http://carpano.it)**